

of chick neural retina cells to extracellular matrix material was inhibited by an antibody against N-CAM and by heparan sulphate⁸. It has now been shown that N-CAM itself has a binding site for a heparin-like proteoglycan⁹. Thus binding of neurones, and perhaps neuronal processes, to extracellular matrix may result from a N-CAM–proteoglycan interaction.

As heparan sulphate has been shown to be on the cell surface of retinal cells, Glaser and co-workers asked whether it might also have a role in the N-CAM-mediated cell–cell adhesion. They found that binding of chick neural retina cells to retinal monolayers was inhibited by heparin but not an unrelated proteoglycan¹⁰. This cell–cell adhesion was also inhibited by the isolated heparin-binding domain of N-CAM and by an antibody that recognizes this domain. As binding of heparin alters the susceptibility of N-CAM to proteolytic cleavage it is thought that the interaction involves a

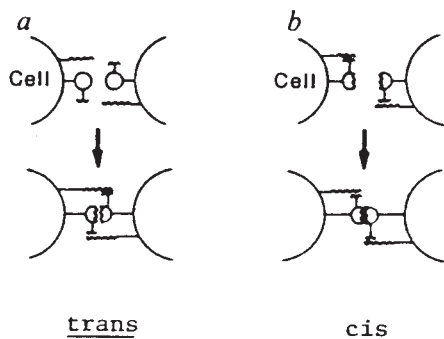

Fig. 2 Possible modes of interaction between heparan sulphate (—) and N-CAM (○). *a*, In a *trans* interaction the heparan sulphate on one cell can interact with the N-CAM on another cell. *b*, in a *cis* interaction the heparan sulphate binds to and possibly modifies the N-CAM on the same cell. (From ref. 10.)

conformational change in N-CAM. What is not yet clear is whether the proteoglycan on one cell interacts with the N-CAM on another cell, or whether the proteoglycan interacts with N-CAM on the same cell and thus affects the affinity of the N-CAM–N-CAM homophilic interaction between cells (see Fig. 2).

These results lead to several conclusions and speculations. One is that the distinction between cell–cell adhesion and cell–substrate adhesion is becoming less distinct. Molecules such as N-CAM may function in both. A second is that

events such as cell adhesion or synapse formation may require several different molecules, and the affinity of each interaction might be modulated by various cellular and extracellular components. Finally, as interactions between adhesion molecules can lead to conformational changes in transmembrane glycoproteins, these molecules may do much more than glue cells together. Cell adhesion, as measured by binding assays *in vitro*, may be an experimental epiphenomenon

rather than a primary driving force in development. Cell interactions through different adhesion molecules may be another source of information — with growth factors and environmental signals — that a cell receives, integrates and translates into the appropriate survival, movement and differentiation response. □

Colin J. Barnstable is in the Laboratory of Neurobiology, Rockefeller University, New York, New York 10021, USA.

Technology

Sedimentological use of dinosaurs

from Michael J. Benton

In films and in fictional literature, massive brontosaurus are pictured crashing through the undergrowth, felling trees as they go, creating seismic tremors as each heavy foot meets the ground. New studies of fossilized dinosaur footprints show how they can be used by geologists to determine ancient water depths, current flows and the slopes of sand dunes. A review¹ of these studies launches the journal *Palaios*, which will be devoted to research on sedimentological and palaeoecological aspects of the fossil record.

Dinosaur footprints are known from dozens of localities around the world. Most research effort so far has been devoted to determining the taxonomy of the tracks and to identification of the track-makers. Specimens produced by every kind of dinosaur have been found, ranging from the tiny bird-like footprints made by small theropods to the vast stump-like marks made by sauropods such as *Brontosaurus*. Palaeobiological interpretations of these trackways have also been made. In many places, for example, multiple tracks show that herds of dinosaurs walked in close formation in the same direction^{1,2}. It has also been possible to calculate how fast the dinosaurs were walking when they made the tracks. The size and spacing of individual prints within a trackway give estimates of speed according to a simple formula³. The fastest 'ostrich' dinosaurs could run as fast as 35–60 km h⁻¹, whereas *Brontosaurus* would have blundered along at 12–17 km h⁻¹ (ref. 4).

The new work on dinosaur footprints focuses on their use in sedimentology. Several authors, for example, have suggested that dinosaur tracks are found largely along the edges of water bodies in close proximity to the strand line^{1,5,6}. The tracks can even be used to reconstruct the exact position of a marine or lacustrine shoreline by measuring the directions of locomotion, which are assumed to be roughly parallel to the shore. In some cases, the footprints within a single trackway vary in depth, the depth of imprint

varying with the water content of the sediment — shallow prints are assumed to indicate dry land and deep prints to indicate where the dinosaur was paddling through shallow water.

Dinosaur tracks can also be used to estimate water depth accurately. If the animal was paddling, the water cannot have been deeper than head height — about 2–3.5 m for a *Brontosaurus* with its neck held horizontally. In other cases, a normal trackway breaks down in deeper water as the animal starts to swim, just touching down on the bottom with a stray foot for steering. There are several examples of sediments which might have been interpreted as having been deposited in deep water but for the dinosaur footprints¹. The direction and power of water currents can also be estimated by observing how a trackway veers sideways from the animal's intended direction of travel (shown by where its toes point). Dinosaur footprints formed on dry land give an indication of the palaeoslope, the slope of the land at that time⁷. On walking up a sand dune, heaps of sand are pushed back by the heels, and on walking downhill, the toes dig in deeper than normal.

What of the smashing and crushing of the habitat caused by dinosaur locomotion? In one case, a brontosaurus trampled across a collection of living unionid clams in shallow water and preserved them for posterity in the base of the huge footprints¹, a sedimentological phenomenon termed *dinoturbation*⁸. □

1. Lockley, M.G. *Palaios* **1**, 37 (1986).
2. Ostrom, J.H. *Palaeogeogr. Palaeoclimatol. Palaeoecol.* **11**, 287 (1972).
3. Alexander, R. McN. *Nature* **261**, 129 (1976).
4. Thulborn, R.A. *Palaeogeogr. Palaeoclimatol. Palaeoecol.* **38**, 227 (1982).
5. McKenzie, D.B. *Mountain Geol.* **9**, 269 (1972).
6. Olsen, P.E., Remington, C.L. & Cornet, B. *Science* **201**, 729 (1978).
7. Leonardi, G. & Godoy, L.C. *Anais 31 Congr. Brasil. Geol. Santa Catarina* **5**, 3080 (1980).
8. Dodson, P., Behrensmeier, A.K., Bakker, R.T. & McIntosh, J.S. *Paleobiology* **6**, 208 (1980).

Michael J. Benton is in the Department of Geology at The Queen's University of Belfast, Belfast BT7 1NN, Northern Ireland.

1. Rutishauser, U. *Nature* **310**, 549 (1984).
2. Edelman, G.M. *A. Rev. Neurosci.* **7**, 339 (1984).
3. Silver, J. & Rutishauser, U. *Dev Biol.* **106**, 485 (1984).
4. Taghert, P.H. & Lichtman, J.W. *Nature* **320**, 111 (1986).
5. Couvaut, J. & Sanes, J.R. *Proc. natn. Acad. Sci. U.S.A.* **82**, 4544 (1985).
6. Sanes, J.R., Schachner, M. & Couvaut, J.J. *Cell Biol.* **102**, 420 (1986).
7. Fallon, J.R. *et al.* *Nature* **315**, 571 (1985).
8. Cole, G.J., Schubert, D. & Glaser, L.J. *Cell Biol.* **100**, 1192 (1985).
9. Cole, G.J. & Glaser, L.J. *Cell Biol.* **102**, 403 (1986).
10. Cole, G.J., Loewy, A. & Glaser, L. *Nature* **320**, 445 (1986).